

LOC		DIST		REVISIONS			
GP	00	P	LYR	DESCRIPTION	DATE	BY	APPD
		R		OBSOLETE -2,-5 PER OS1D-0014-00	2MAY01	AH	JR

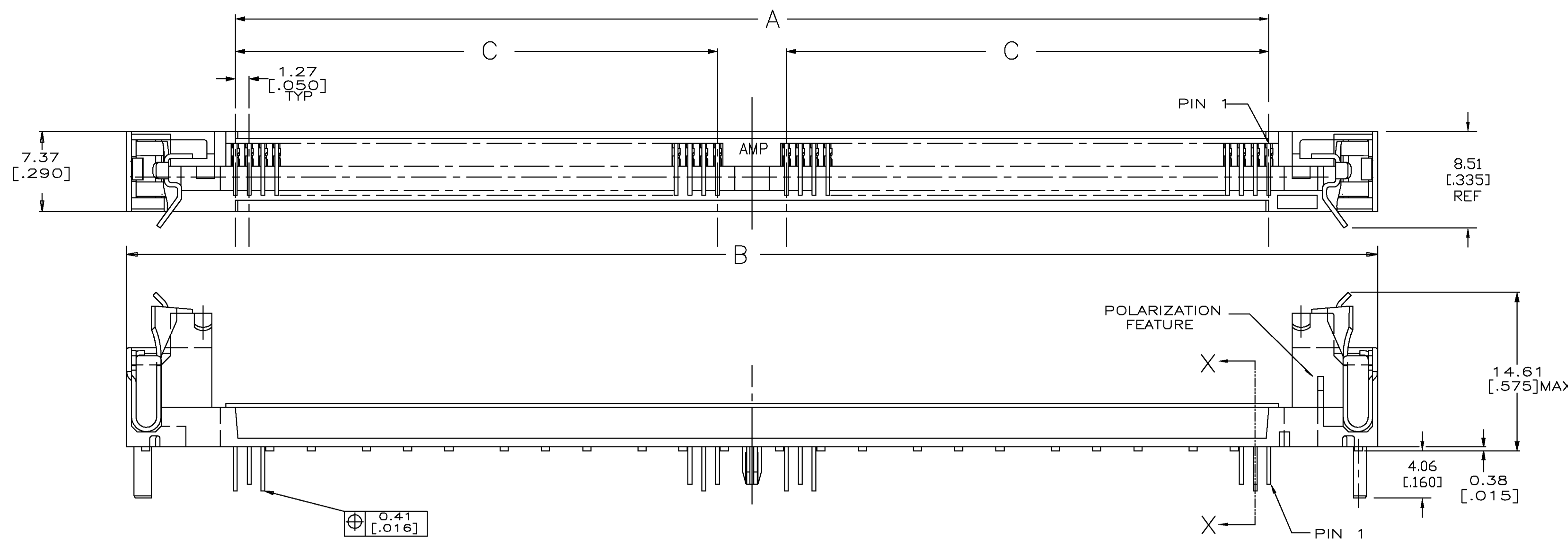

- △ HOUSING-MATERIAL : LIQUID-CRYSTAL-POLYMER.
  - △ CONTACT-MATERIAL : PHOS. BRONZE.
  - △ LATCH-MATERIAL : BRASS, NICKEL PLATE.
  - △ CONTACT-PLATE 0.00127 [.000050] MIN NICKEL ALL OVER.
  - △ CONTACT-PLATE 0.00076[.000030] MIN. GOLD AT CONTACT PTS.
  - △ CONTACT SOLDERTAILS-PLATE 0.00508[.000200] MIN TIN/LEAD.
7. IN ADDITION TO THOSE RECOMMENDED "SIMM" P.C. BOARD DIMENSIONS AND TOLERANCES SHOWN, ALL JEDEC SPECIFICATIONS APPLY AS SHOWN ON MO-116, ISSUE A.
8. RECOMMENDED MATING S.I.M.M. TAB METALLURGY:  
 BASE METAL-COPPER. PLATING TO BE 0.00076[.000030] MIN GOLD OVER 0.00127[.000050] MIN NICKEL.

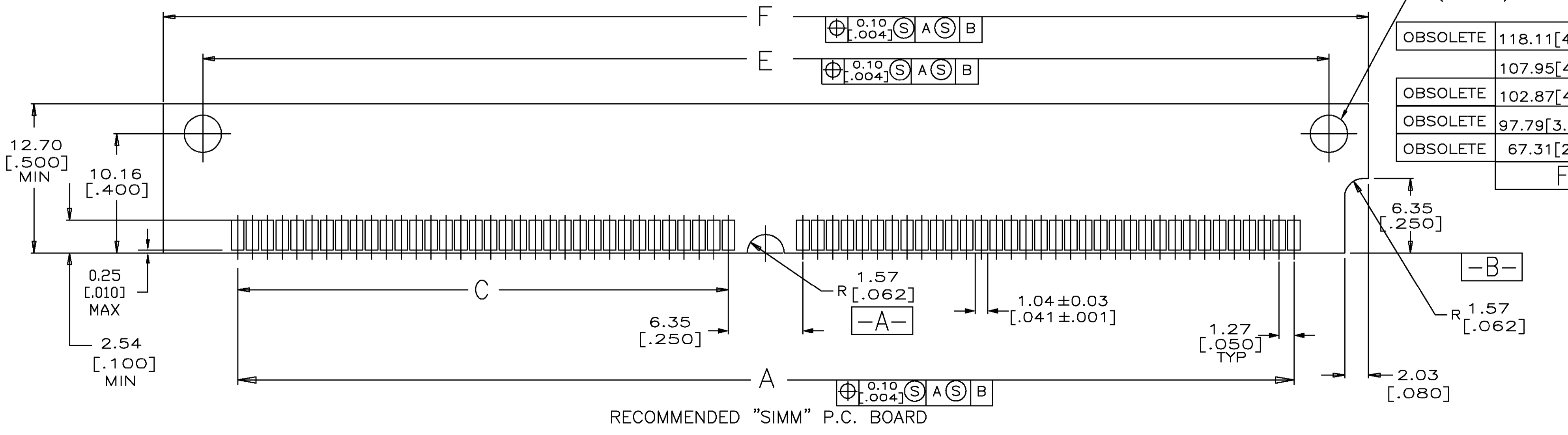
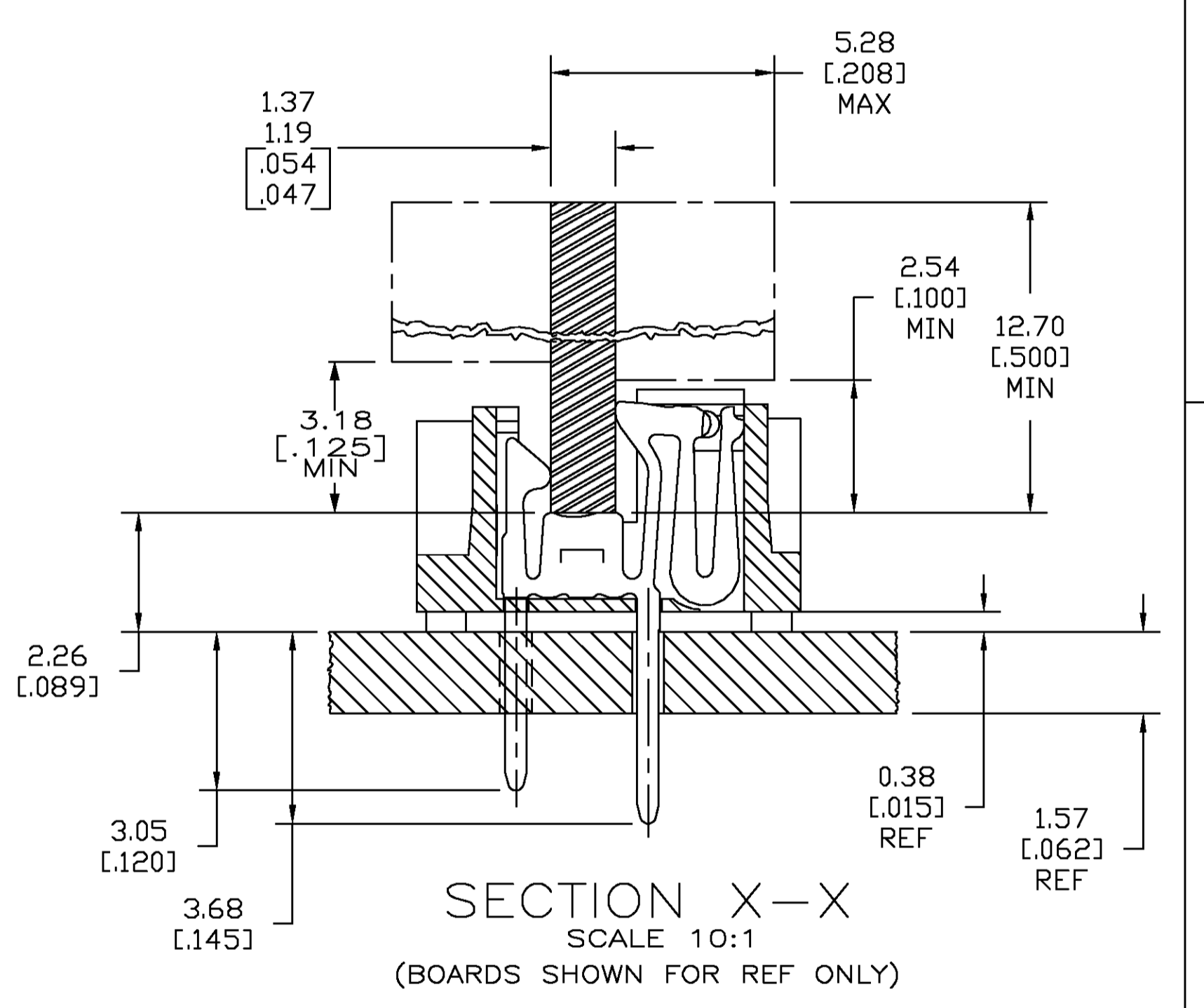
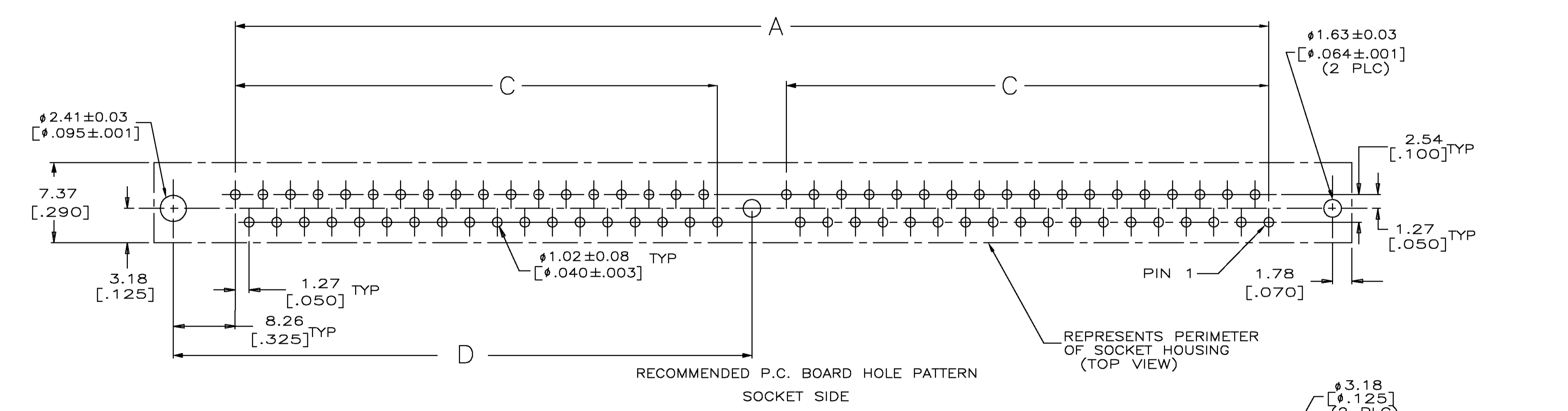

OBSOLETE	118.11[4.650]	111.35[4.384]	60.96[2.400]	49.53[1.950]	125.73[4.950]	105.41[4.150]	80	822032-5
OBSOLETE	107.95[4.250]	101.19[3.984]	55.88[2.200]	44.45[1.750]	115.57[4.550]	95.25[3.750]	72	822032-4
OBSOLETE	102.87[4.050]	96.11[3.784]	53.34[2.100]	41.91[1.650]	110.49[4.350]	90.17[3.550]	68	822032-3
OBSOLETE	97.79[3.850]	91.03[3.584]	50.80[2.000]	39.37[1.550]	105.41[4.150]	85.09[3.350]	64	822032-2
OBSOLETE	67.31[2.650]	60.55[2.384]	35.56[1.400]	24.13[.950]	74.93[2.950]	54.61[2.150]	40	822032-1
	F	E	D	C	B	A	NO OF POSN	PART NO

THIS DRAWING IS A CONTROLLED DOCUMENT. DIM: K.SALMON 2-25-91  
 CHK: R.MILLER 2-25-91  
 APPD: J.LAMBERT 2-25-91  
 NAME: AMP INCORPORATED  
 HARRISBURG PA 17105-3608

AMP  
 AMP Incorporated  
 Harrisburg PA 17105-3608

CONNECTOR, MICRO-EDGE, .050, VERT, GOLD PLATING, W/METAL LATCH

PRODUCT SPEC: APPLICATION SPEC

SIZE: A1 GAGE CODE: 00779 DRAWING NO: C-822032

MATERIAL: WEIGHT: RESTRICTED TO: CUSTOMER DRAWING SCALE: 4:1 SHEET: 1 OF 1 REV: R